



# Ford Shelby GT500 Supercharged 5.4-Liter Aluminum-Block V-8

The 2011 Ford Shelby GT500® is powered by an all-new aluminum-block 5.4-liter supercharged V-8 engine offering an improved weight savings of 102 pounds off of the outgoing cast-iron block. The weight savings helps improve fuel economy, acceleration, handling and steering precision. Advanced engine manufacturing techniques and refined tuning also help produce 550 horsepower – a 10 hp increase over the 2010 model – and 510 ft.-lb. of torque.



## Plasma Transferred Wire Arc (PTWA) cylinder liner technology

The 5.4-liter aluminum-block engine uses a Ford-patented Plasma Transferred Wire Arc (PTWA) cylinder liner coating, a process that applies a 150-micron



Photo Courtesy of IOT

composite coating containing nanoparticles on the internal surfaces of engine cylinder bores, replacing the cast-iron liners typically used in aluminum engine blocks.

The PTWA process uses air and electricity to create a plasma jet of 35,000 degrees F, which melts a steel wire that is fed into a rotating spray gun. Using atomized air, the melted steel wire is blown onto the engine cylinder bores, which have been specially machined to receive the coating. In the process of melting and applying the metal to the surface, the steel wire oxidizes, creating a composite consisting of both iron and iron oxide.

**NEW INTERCOOLER** – A larger two-row intercooler system, which has 40 percent more heat-rejection capacity, helps make power more consistent in higher ambient conditions.

### ENGINEERED FOR PERFORMANCE

– The lighter aluminum block is reinforced with structural webbing, a unique bulkhead chilled process and incredibly strong six-bolt billet main bearing caps for high-performance durability; larger oil drainbacks and an integrated windage tray improve oil control in extreme conditions.

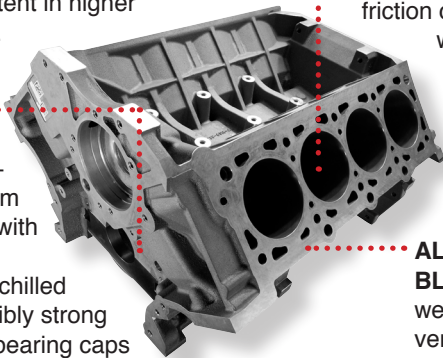

**PTWA CYLINDER LINERS** – Aerospace technology results in a durable, low-friction cylinder bore lining without the weight of traditional iron liners; improved heat transfer also results in better engine cooling.

**ALUMINUM ENGINE BLOCK** – Reduces weight by 102 pounds versus cast-iron block for improved acceleration, fuel economy and handling.

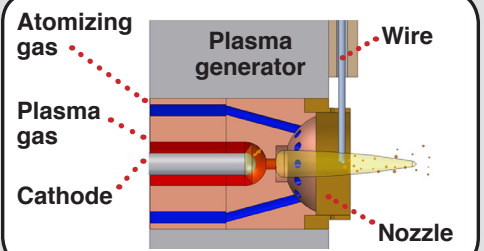

Photo Courtesy of IOT

PTWA coating offers improved performance and durability versus iron liners, along with functional benefits of reduced friction between piston rings and cylinder bores, improved heat transfer due to increased surface contact area, and a weight savings of 8.5 pounds over a typical sleeved aluminum block.

The Intellectual Property Owners Education Foundation honored the inventors of the Ford-patented PTWA technology with the 2009 National Inventor of the Year award.

## Fuel economy improvements

With a projected 23 mpg highway and 15 mpg city, the 2011 GT500 is expected to become the first modern Shelby GT500 that will not be subjected to the gas guzzler tax. Improved fuel economy stems from the lighter aluminum-block engine, Electric Power Assist Steering and detailed aerodynamic changes to the undercarriage.

